



 **direct to garment & screen print**

CONVEYOR DRYERS

The Professional Conveyor That More than Fits the Bill

- 30 sec. - 6 min. cure time, it's up to you
- Designed in conjunction with digital to garment printer manufacturers
- Color remains vibrant and intense
- Higher production output than a heat press
- Digital temperature and speed controls
- One year warranty on elements
- Designed for digital inks, Excellent for water-based and plastisol inks

DIGI-CURE[™]



Features

Forced Air Flow



Dual Zone Heat Control

DIGITAL SPEED CONTROL

Performance on Colored Shirts



35 Shirts/hr @ 6 min. in Chamber

40 Shirts/hr @ 5 min. in Chamber

60 Shirts/hr @ 3.5 min. in Chamber

80 Shirts/hr @ 2.5 min. in Chamber

Specifications

Model	AIR-2411-240V
Length	132"
Width	34"
Height	42"
Belt Width	24"
Belt Height	30.8"
Belt Speed Digital Control	1-16 FPM
Chamber Length	94"
Heating Elements	Combo IR/Convection
Heater Wattage	13375 Watts
Heater Power Req.	240 VAC, 55.8 Amps
Shipping Weight (Approx.)	320 lbs.
Heat & Speed Control	Digital

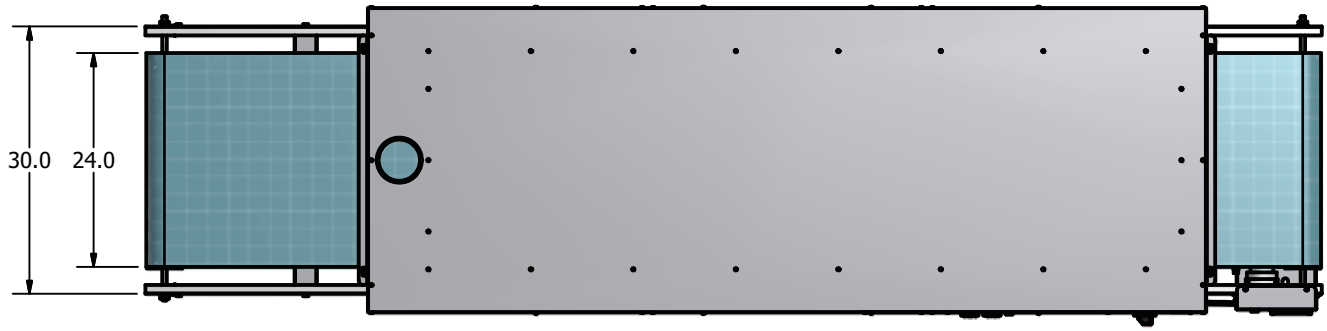

Product Flow →

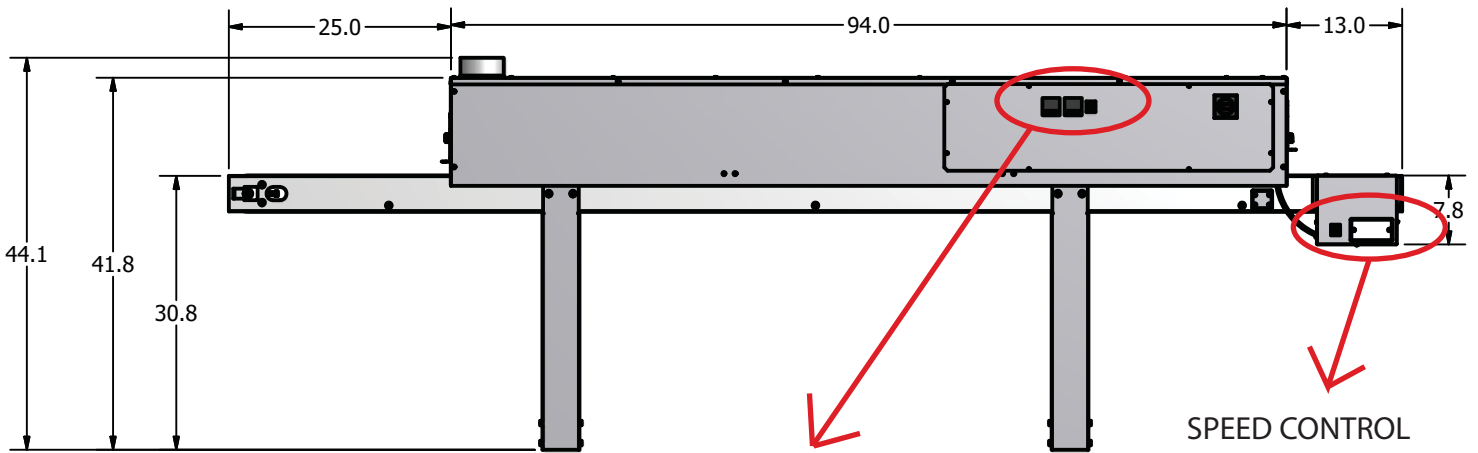

SPEED CONTROL

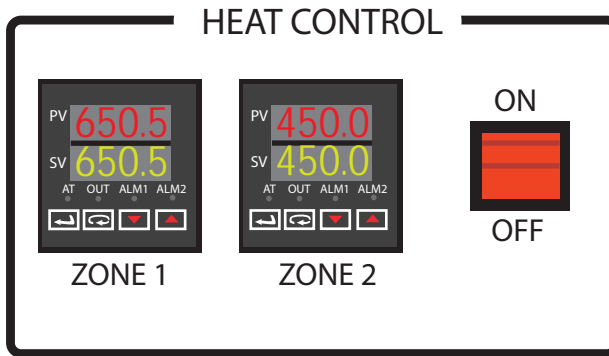
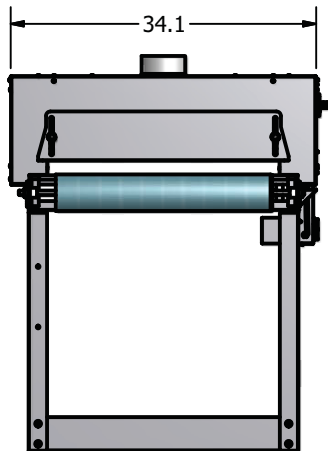
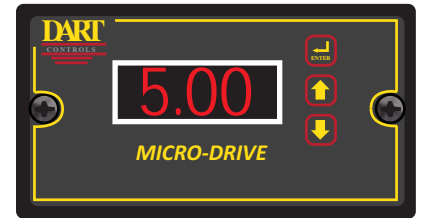

Black Body
INFRARED DRYING SYSTEMS®

BBC INDUSTRIES INC.
5 CAPPER DRIVE
PACIFIC, MO 63069 USA
636-343-5600 FAX 636-343-3952
800-654-4205 WWW.BBCIND.COM