



DIGI-DRY PRINTER DUAL STAND ASSEMBLY

ORIGINAL DOCUMENT

ASSEMBLY INSTRUCTIONS:

1. Remove hardware shown from upright.
2. Rotate the upright to vertical and align the hole in the upright with the slot in the base plate.
3. Re-install hardware thru base plate into the upright as shown with the larger washer on the same side as the carriage bolt & base plate.
4. Tighten adjustment knob.
5. Repeat steps 1 - 4 on opposite side.
6. Install heater head per Digital Dryer Assembly Instructions.

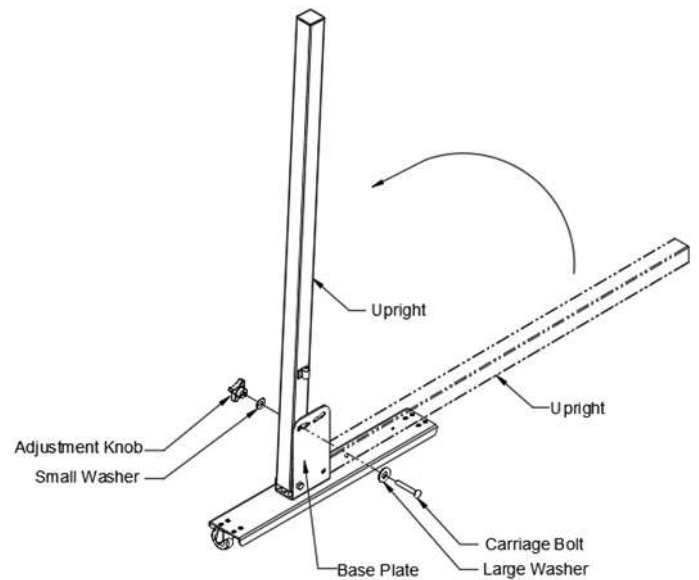

Please contact the service department at *BBC Industries* (800-654-4205) or service@bbcind.com with any questions regarding these instructions.